

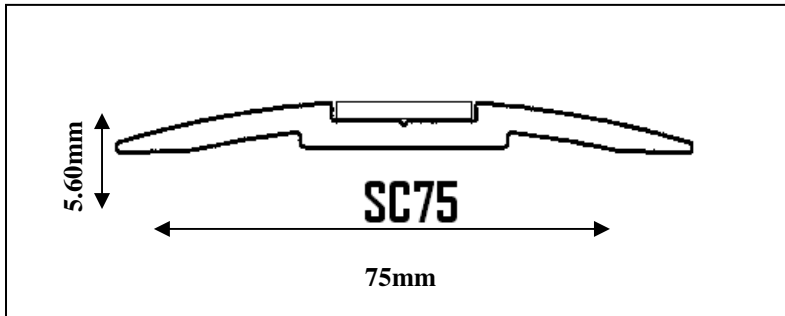

pathfindersystems

PRODUCT INFORMATION SHEET

STAIR NOSING – COVER STRIPS – ANTI SLIP TAPE

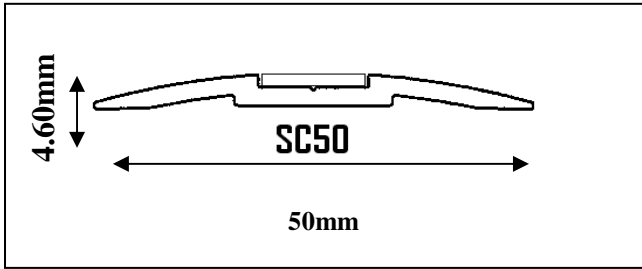

SC50 and SC75 Slim-Line Floor Cover Strips with secret fittings have been designed for smooth transition between different flooring surfaces. The initial design spec was to facilitate wheel chair access between rooms with vinyl flooring and carpeted corridors in a medical facility. The profiles have a smooth finish to reduce bacteria from forming. The cover strips are of a solid design for commercial installations, but would also suit domestic applications such as thresholds.

Aluminium Our profiles are extruded from 6060/T5 Alloy; this can be interchanged with 6063/T5. Both alloys are architectural grade with good surface finish and very good corrosion resistance.

Anodising Aluminium profiles are anodised 15 – 20 microns in accordance with AS 1231:2000. Available in Clear Anodised (Natural Silver).

Aluminium Inserts The insert is a 1.6mm x 12mm aluminium bar, anodised to match the profile. It is held in place with double-sided tape.

Standard Length The SC50 and SC75 are available in 4 metre lengths. Cover strips can be cut to size and supplied ready for installation.

Custom Made Profiles We offer a design and manufacture service for specific applications. Please contact us for further information.

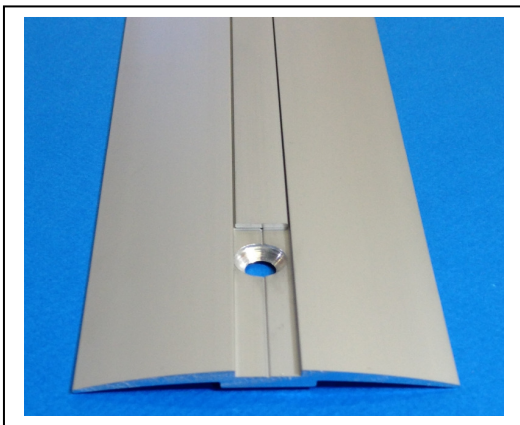

Pathfinder Systems Australia Pty Ltd, Unit 3, 95 Jemma Road, Prestons NSW 2170

Phone:- 02 9608 5249

Fax:- 02 8783 7869

Email:- sales@pathfindersystems.com.au website: www.pathfindersystems.com.au